



**LOYOLA  
MEDICINE**

---

*Loyola University Chicago  
Stritch School of Medicine*

**FAMILY MEDICINE**  
**Third-Year Clerkship**  
**STUDENT SYLLABUS**

## TABLE OF CONTENTS

### Clerkship Overview

Welcome to Family Medicine	3
Faculty and Staff Information	4
Learning Objectives and Competencies	5-8
Clerkship Structure	
1. Orientation	9-10
2. Weekly Checklist	11
3. Tips for Enhancing Your Clerkship Experience	12

### Clerkship Assignments and Requirements

Clinical Responsibilities	12
Patient Log	13-15
Procedural Checklist and Critical Incidents	16
The Procedural Checklist/Critical Incidents form is located in your Orientation folder.	
Biopsychosocial Project	17-28
Mid-Rotation Evaluation Form – located in pocket of your orientation folder	
Education Contract – located in the pocket of your orientation folder	
Evidence-Based Medicine (EBM) Project	30-41
Clinical Skills Exercise	42-43

### Grades, Required Reading, and Evaluation

Overall Course Grade	44
Studying for Final Exam	44
Self-Study – Not on the Final Exam	45
Student Evaluation of the Clerkship	45-46

Career-Related Information	46-48
----------------------------	-------

# CLERKSHIP OVERVIEW

## Welcome to Family Medicine

The Loyola Department of Family Medicine welcomes you to the Family Medicine Clerkship. The faculty and staff hope you have an educationally valuable as well as enjoyable experience!

Since July 1995, the Family Medicine Clerkship has been required for all third-year Loyola students. Planning for the clerkship began when the Dean formed the Department of Family Medicine in response to students' requests for a department and more formalized Family Medicine education. In addition, the LEEP project highlighted the need for more ambulatory and primary care education throughout the four years of medical school. In designing and developing this clerkship, we have gotten input from a number of Loyola students and educators, as well as from family physicians practicing and teaching locally and nationally. Your input will be important if we are to continue to improve the clerkship. We hope the clerkship meets your needs and provides you with an introduction to the specialty of Family Medicine.

We have designed the manual to assist you in getting the most out of your experience. It includes a description of all requirements for the clerkship, as well as information that will help to introduce you to Family Medicine. The manual outlines the specific competencies that we hope you will be able to accomplish. Your main responsibilities should be to:

1. **Learn about common ambulatory problems encountered by family physicians.**
2. **Understand the primary care physician's role in patient care.**
3. **Implement a biopsychosocial model in caring for patients.**
4. **Implement health promotion and disease prevention in caring for patients.**

Since Family Medicine is largely an ambulatory-based specialty, the clerkship focuses primarily on ambulatory experiences. However, family physicians do maintain continuity of patient care from the office to the hospital and therefore your experience may include some time spent in the hospital making rounds on the practice's patients, taking call, or assisting with a delivery. During your rotation, you will quickly realize that primary care medicine is different from the hospital world.

We have selected a variety of Family Medicine sites and physicians to participate in your educational experience. We have tried to match you with locations that meet your preferences as best possible. Although we expect your experiences to vary based on your setting, all locations should provide a quality experience.

Finally, we cannot emphasize strongly enough how important your safety and concerns are to us. **If you are experiencing any problems during the clerkship**, please alert us immediately.

## Faculty and Staff Information List

1. **Department Location**

Loyola University Medical Center  
Department of Family Medicine  
2160 South First Avenue  
Fahey Building 54, Rm. 252  
Maywood, Illinois 60153

2. **Clerkship Location**

Loyola University Chicago  
Stritch School of Medicine  
2160 South First Avenue  
Building 120, Rm. 320  
Maywood, IL 60153

**Clerkship Phone: 708-216-2109**  
**Clerkship Fax: 708-216-5318**

### Clerkship Faculty and Staff

Scott Levin, MD  
Clerkship Director  
Associate Clinical Professor  
[slevin@lumc.edu](mailto:slevin@lumc.edu)

Kit Lee, MD  
Associate Clerkship Director  
Assistant Professor  
[klee2@lumc.edu](mailto:klee2@lumc.edu)

Amy Andel  
Medical Education Coordinator  
708-216-2109  
[aandel@lumc.edu](mailto:aandel@lumc.edu)

### Department Faculty

Aaron J. Michelfelder, MD, FAAFP, FAAMA  
Professor and Chair  
Department of Family Medicine  
[amichel@lumc.edu](mailto:amichel@lumc.edu)

## Learning Objectives and Competencies

Although the Family Medicine Clerkship will be conducted at a variety of clinical sites in different settings, all students are expected to accomplish a core group of competencies. These competencies are based in three major domains: Patient Care, Health Promotion and Disease Prevention, and Professionalism.

### a. Medical Knowledge

1. Individualize effective screening recommendations for a woman over 40, in for her annual exam.
2. Individualize effective screening recommendations for a man over 40, in for his annual exam.
3. Understand the assessment, differential diagnosis and initial treatment for insomnia in the elderly, including knowledge of major depressive disorder, and elderly abuse.
4. Understand the assessment, differential diagnosis and initial treatment of common joint injuries, with special attention to the ankle joint.
5. Understand the assessment and differential diagnosis for palpitations, with special attention to the diagnosis and treatment plan for hyperthyroidism.
6. Individualize effective assessment and treatment plans for patients with type II diabetes mellitus.
7. Understand the assessment and differential diagnosis for unilateral leg swelling, with special attention to the diagnosis and treatment plan for deep venous thrombosis.
8. Individualize effective assessment and treatment plans for patients with hypertension.
9. Understand risk factors for coronary heart disease, and effectively stratify patients with those risks, based on history, physical exam, and testing strategy.
10. Understand the assessment, differential diagnosis and initial treatment of patients with low back pain.
11. Understand the assessment and differential diagnosis for knee pain, with special attention to the diagnosis and treatment plan for osteoarthritis.
12. Individualize effective counseling, assessment, and management of teenage pregnancy and its complications.
13. Understand the assessment and differential diagnosis for an adult with persistent cough, with special attention to the diagnosis and treatment plan for asthma and its co-morbid conditions.
14. Understand the diagnosis, dating, and management of intrauterine pregnancy, including complications such as hypertension, preeclampsia, gestational diabetes, vaginal bleeding, domestic violence, and depression.
15. Understand the assessment and differential diagnosis for right upper quadrant pain, with special attention to the diagnosis and management of biliary tract disease, and counseling for alcohol abuse.
16. Effectively describe skin lesions, understand the treatment principles of topical agents, the specific characteristics of more common skin cancers, along with biopsy options, and preventive measures.
17. Individualize effective assessment and treatment plans for patients with benign prostatic hypertrophy.
18. Individualize effective screening, counseling, assessment, and treatment plans for women who have reached menopause, with special attention to post-menopausal bleeding, osteoporosis, and hormone therapy.
19. Understand the assessment, differential diagnosis, and treatment plans for patients with headache.
20. Understand the assessment, differential diagnosis, and treatment plans for patients with epigastric pain, with special attention to peptic ulcer disease, H. Pylori gastritis, and gastroesophageal reflux disease.
21. Individualize effective assessment and counseling of those exposed to domestic violence.
22. Understand the assessment, differential diagnosis, and treatment plans for patients with an acute respiratory infection, with special attention to bacterial pneumonia.
23. Individualize effective assessment, counseling, and treatment plans for pediatric patients with obesity.
24. Understand the assessment, differential diagnosis, and treatment plans for patients presenting with new onset neurologic symptoms, with special attention to transient ischemic attack, stroke, and stroke prevention.

25. Understand the assessment, differential diagnosis, and treatment plans for pediatric patients with pharyngitis, with special attention to viral pharyngitis and strep throat.
26. Recommend appropriate screening and preventive measures for pediatric patients, based on age, with special attention to immunizations and anemia.
27. Individualize effective assessment and treatment plans for newborns and their parents during the immediate post-partum period, with special attention to the normal newborn exam, post-partum blues, post-partum depression, and breastfeeding.
28. Understand the assessment, differential diagnosis, and treatment plans for patients with fatigue, with special attention to iron deficiency anemia.
29. Understand the assessment, differential diagnosis, and treatment plans for patients with scrotal pain, with special attention to testicular torsion, and sexually transmitted illness.
30. Understand the assessment, differential diagnosis, and treatment plan for patients with shortness of breath, with special attention to chronic obstructive pulmonary disease (COPD).
31. Individualize effective assessment, treatment plans, and counseling for elderly patients with dementia and/or delirium, including caregivers.
32. Understand the diagnosis of active labor, and interpret fetal monitoring strips.
33. Understand the assessment, differential diagnosis, and treatment plans for patients with congestive heart failure.
34. Individualize effective assessment, treatment plans, and counseling for patients with dysmenorrhea, with added attention to premenstrual syndrome.
35. Understand the assessment, differential diagnosis, and treatment plans for patients with dizziness and vertigo.
36. Understand the important aspects of prenatal screening, with special attention to TORCH infections, HIV transmission, and etiologies for small-for-gestational-age (SGA) infants.
37. Individualize effective assessment, counseling, and treatment plans for pediatric patients with asthma.
38. Understand the assessment, differential diagnosis, and treatment plans for patients with chest pain, with special attention to angina pectoris, atypical angina, non-cardiac chest pain, and secondary prevention of ischemic heart disease through the reduction of cardiovascular risk factors.
39. Individualize effective assessment, counseling, and treatment plans for patients with obesity, with added attention to dyslipidemias.

## **b. Communication Skills**

1. Write a coherent history and physical, or SOAP note.
2. Clearly present a patient's history and physical exam.
3. Effectively talk to patients and their families, especially in difficult situations, i.e. end of life issues.
4. Motivate and instruct patients in health promotion and disease prevention.
5. Demonstrate an understanding of how family, culture, and religious beliefs can influence healthcare decisions and outcomes.
6. Respectfully and effectively communicate issues of patient care with non-physician healthcare workers, including clergy.
7. Explain to patients and families, findings from clinical investigations, including plans for follow up, possible courses of therapy with indications, risks, and benefits, and alternatives.
8. Collaborate with fellow students, healthcare professionals, patients and families. Including strategies for teaching in small groups, especially giving feedback.\

## **c. Professionalism**

1. Demonstrate an effective physician-patient relationship to provide quality health care and understand the therapeutic role these relationships confer.
2. Understand the major obligations of physicians to their patients and show skill and service to people who come for care for a variety of reasons.

3. Demonstrate advocacy for patients over personal interests.
4. Display behaviors that foster patient trust in the physician, by appropriate dress, grooming, punctuality, honesty, respect for patient confidentiality, and other norms of behavior in professional relationships with patients
5. Converse appropriately and behave with personal integrity in all course and clerkship activities and in interactions with peers, faculty, residents, and non-physician staff and identify these interactions as analogs of future professional relationships thereby maintaining the same high standards expected in patient care.
6. Work collaboratively as members of a healthcare team in a variety of settings.
7. Demonstrate commitment to and examples of service to patients in need.
8. Recognize and accept their own limitations in knowledge and clinical skills and commit to continuously improve their knowledge and ability.

#### **d. Patient Care**

1. Perform, record, present and interpret a complete screening physical exam.
2. Effectively observe, communicate, and interact with patients, families, and other healthcare workers to obtain histories, deal with difficult situations, and insure proper record keeping.
3. Integrate data from the history, physical, and laboratory to construct a problem list, develop a prioritized differential diagnosis along with therapeutic, diagnostic, and patient education plans for each problem identified.
4. Make clinical decisions and solve problems using deductive reasoning based on data obtained about the patient, principles of clinical epidemiology, and evidence-based medicine.
5. Construct appropriate management strategies (diagnostic, therapeutic and behavioral) for common conditions, both acute and chronic
6. Develop care plans for patients with chronic conditions not amenable to immediate cure, including: rehabilitative services, care of chronically disable persons and patient facing the end of life.
7. Interpret the results of the most frequent commonly used clinical laboratory tests.
8. Perform relevant routine clinical exams and procedures including:
  - a. Breast Examination
  - b. Testicular Examination
  - c. Pelvic examination and PAP smear
  - d. Skin exam
9. Exhibit an understanding of how to perform database retrievals, retrieve patient-specific information, select and use information technology, and employ electronic communications for the direct care of patients.

#### **e. Practice Based And Lifelong Learning**

1. Demonstrate knowledge of specific topics related to students' patients and use the medical literature to gather relevant information for patient care.
2. Use information technology to access and manage clinical information and perform on-line searches to support ongoing self-directed learning.
3. Search, evaluate, and critically review scientific evidence appropriate to the care of individual patients or as an approach to a clinical problem
4. Demonstrate an understanding of the variations in physician behavior for common conditions, the importance of developing evidence-based practice methodology to lessen variations, the role of practice pathways to manage common problems, and the need to individualize recommendations for the patient.
5. Formulate questions regarding outcomes seen in patient care and consider simple methods of quality improvement including improved patient satisfaction, decreased

complication rates, improved clinical outcomes, and improved access to healthcare for patients from underserved groups.

6. Demonstrate a commitment to identifying errors in medicine, reasons for errors, and develop basic strategies to reduce medical errors.
7. Demonstrate a plan for professional growth.

**f. Social And Community Context Of Healthcare**

1. Demonstrate an understanding that some individuals in our society are at risk for inadequate healthcare, including the poor, uninsured, underinsured, children, unborn, single parents, elderly, racial minorities, immigrants, refugees, physically disabled, mentally disabled, chemically dependent, and those with incurable diseases.
2. Demonstrate an understanding of the impact of economic and health insurance issues on patient care.
3. Under supervision, develop diagnostic and treatment strategies that are cost-effective, sensitive to limited resources, and do not compromise quality of care.
4. Appropriately recommend use of consultants and referrals.
5. Demonstrate knowledge of non-biological determinants of poor health including child abuse, domestic violence, and the economic, psychological, social, and cultural factors that contribute to their development and continuation.
6. Demonstrate an understanding of economic, psychological, social, and cultural factors that impact patient health.

**\*Learning Objectives for the individual fmCASES are linked to the “Medical Knowledge” on the Family Medicine LUMEN website.**



# Clerkship Structure

## Introduction

The clerkship is six weeks in length, beginning with one day of orientation and concluding with the online clerkship exam. There are two types of sites available to students. One site may be a private practitioner's office, while the other clinical experience involves working at ambulatory care centers associated with Family Medicine residency training programs. These experiences offer similar but not identical experiences. Please remember the preceptors are volunteer teachers; always remain courteous and respectful of both patients and office staff.

### 1. Orientation

**Loyola Orientation.** During the first day of the clerkship, a general orientation is scheduled at the Loyola campus. Most orientation sessions begin on a Monday, unless there is a legal holiday. **All** students are expected to attend the **entire** orientation. The Clerkship Director must approve any absence.

At the Loyola orientation, the clerkship syllabus will be reviewed. The orientation will also include didactic sessions and interactive activities that should assist you in your rotation and required projects. Topics covered during the orientation might include:

- Adolescent Health
- Asthma Management
- Community/Underserved Medicine
- Diabetes Management
- Domestic Violence
- History of Family Medicine
- Musculoskeletal Medicine
- Obesity Management
- Male Sexual Function Issues
- Sports Medicine
- Prostate Screening
- Women's Health

**On-site Orientation.** Each clerkship site has an assigned faculty member responsible for your educational experience. When you arrive at your clinical site you will meet with your preceptor/supervising attending. Plan to review your "Important Dates to Remember" page with your assigned preceptor. We expect students to spend at least 30 hours per week in direct ambulatory care, with the remaining time used for reading and completing assignments and projects, rounding on inpatients, attending educational programs, etc. Residency-based programs usually offer a more formal orientation to the site. You should discuss with your preceptor how your time will be allotted at this first meeting. You should think about what your personal goals are for the clerkship.

If it is not immediately clear who your assigned preceptor is please notify the Site Director or Clerkship Director as soon as possible. We expect each student to have a preceptor who is ultimately responsible for his/her experience. If you are in a "private office" you should meet with this person virtually every weekday. The only exception will be if your preceptor is on vacation or is off one day per week. In this case, your preceptor may assign another attending to meet with you on those days. At residency practices, you will work with a number of residents and attendings. However, you should meet with your supervising attending at least twice per week.

**Educational Programs On-site.** The residency program faculty may plan educational programs unique to its site. Examples may include lectures or visits to a health department program or nursing home. Attendance is mandatory if required by the supervising faculty. Each preceptor may also offer unique experiences of which we encourage students to take advantage such as attending hospital staff or department meetings or attending continuing medical education programs. The preceptor should also assist you in identifying patients who are suitable for your projects. If you find it difficult to select appropriate patients or topics for your projects, inform the Education Coordinator.

**Attendance.** See the Academic Policy Manual, page 31, for the SSOM policy on clerkship attendance. Should the Loyola policy differ from that of your assigned site, please inform the Education Coordinator. In most cases, the Loyola policy takes precedence over the clerkship site policy. The Clerkship Director must approve any known absences, in advance. Written documentation, such as a copy of a wedding invitation, airline tickets or a program, must be provided. **Any illness that leads to time away from the clinical clerkship should be immediately reported to the clerkship coordinator and clerkship director.** If a student misses any amount of time due to illness, the student **MUST** report to the **Student Health Clinic** for clearance prior to returning to clinical activities. Any clinical time missed, and subsequently cleared through the Student Health Clinic, will not negatively impact a student's clinical performance evaluation. **However, missed time, even when excused, may need to be made up, at the discretion of the individual clerkship director.**

**Too Tired To Drive Home Policy.** If, for any reason, you are too tired to safely drive, you can obtain a taxi ride to your home. While at Loyola or Hines, go to the Loyola.wired web page (<http://portal.luhs.org>) and login to the **INFORMATION PORTAL**. Click on the **Way To Go! Taxi Voucher** link for taxi Service. When at other sites, call a taxi, pay, and bring the receipt to Dr. Gruener's office (SSOM, Room 310) for reimbursement. A ride back to the hospital is also underwritten.

**Eighty-hour work week.** Your total time at a clinical site cannot exceed 80 hours/week. This includes "call" not more than every fourth night and a minimum of one full day off/week. For violations, notify the Site and Clerkship Director.

**Blood Borne Pathogen Exposure.** If you are stuck by a needle or other sharp object, or get blood or other potentially infectious materials in your eyes, nose, mouth, or on broken skin, immediately flood the exposed area with water and clean any wound with soap and water or a skin disinfectant. Report this immediately to a supervisor, indicating the person who needs to be source tested. You should seek immediate medical attention. If at Loyola, report the exposure to the Loyola Outpatient Center (LOC) Employee and Student Health Clinic at 708-216-3156 for further instructions. If after hours, on weekends, or holidays, (1) report to the Emergency Department **and** (2) leave a secure voicemail message for the LOC Employee and Student Health at 708-216-2312. State your name, date of birth, phone number, and name and medical record number of the person who was the source of exposure. If off campus, contact the site's employee/occupational health service immediately or go to their Emergency Department. Your insurance information will need to be provided.

**Non-Sexual/Sexual Harassment/Mistreatment.** Stritch has a policy of zero tolerance for such treatment. For instances of non-sexual mistreatment, you are encouraged to find support with a variety of resources, including the Clerkship Director, Campus Ministry/Pastoral Care, personal counseling services, our Medical Center Employee Assistance Program (EAP) counselors, any of the deans or trusted faculty. If you believe that the issue needs more formal investigation/resolution, you should contact the Associate Dean for Student Affairs. In instances of Sexual Harassment, Stritch is governed by our Medical Center's Sexual Harassment Policy and all allegations of sexual harassment must be formally investigated. You may seek confidential consultation through the EAP or Office of Campus Ministry to explore options for addressing the concern, and you are strongly encouraged to notify the Associate Dean for Student Affairs.

**2. Weekly Checklist:** The following checklists are to assist you in progressing smoothly through your rotation and to make sure you complete all of the assignments on time.

### **Week One**

- Review initial responsibilities.
- Review competencies.
- Familiarize yourself with the staff and their responsibilities.
- Find out about your office space, parking, and meals. Get ID badges and other administrative responsibilities accomplished, depending on site.
- Review general office policies, including charting, dictation, and the appointment system.
- **Start working on the Family Medicine CASES:** <https://aquifer.org>, & Working w/ Families Article.
- Read the syllabus and be familiar with all required assignments, and discuss with your preceptor.
- At the end of the week, discuss with the preceptor how things are going and discuss your goals.
- Complete and sign your educational contract, and discuss with your preceptor.
- Fill out the log card and any critical incidents at the end of each day.
- Enter patient data into the portal.

### **Week Two**

- If you are not seeing patients on your own, request that you begin to do so.
- Identify a suitable patient for the biopsychosocial assignment and arrange for an interview to carry out the assignment.
- Begin to complete your Procedural Checklist.
- **Continue Family Medicine CASES:** <https://aquifer.org>, & Working w/ Families Article.
- Review your initial personal goals and performance to date with the primary preceptor.
- Identify a clinical question for the Evidence-Based Medicine (EBM) assignment and clear it with your preceptor. You may then start the Library Module, which takes 45-60 minutes to complete.
- Enter patient data into the portal.

### **Week Three**

- Make sure you are seeing at least 3-5 patients per half-day session on your own and writing SOAP notes for them.
- Make sure you are about halfway through your Procedural Checklist by the end of the week.
- **Continue Family Medicine CASES:** <https://aquifer.org>, & Working w/ Families Article.
- **Ask preceptor to discuss, complete and sign your mid-rotation evaluation.**
- If not already completed, interview your patient for the Biopsychosocial Project. Complete the written portion of the assignment and prepare for oral presentation to the group at SSOM.
- Present your Biopsychosocial Project at Loyola and be prepared to discuss how things are going with the faculty facilitator.
- Enter patient data into the portal.

### **Week Four**

- **Continue Family Medicine CASES:** <https://aquifer.org>, & Working w/ Families Article.
- Continue to work on the EBM assignment. Make sure you have completed the Library Module.
- Enter patient data into the portal.

### **Week Five**

- Continue completing your Procedural Checklist.
- **Continue Family Medicine CASES:** <https://aquifer.org>, & Working w/ Families Article.
- Review your log card. If obvious gaps in certain types of patient problems are seen, discuss with preceptor and try to rectify.
- Make sure you are seeing at least 6-8 patients per half-day session on your own and writing SOAP notes for them.
- Enter patient data into the portal.

### **Week Six**

- **Complete all required Family Medicine CASES:** <https://aquifer.org>, & Working w/ Families Article.
- Complete EBM assignment and turn it in at your final exam.
- Elicit feedback from your preceptor on your clinical evaluation.
- Prepare for final exam.
- Enter patient data into the portal.

### 3. Practical Tips for Enhancing Your Clerkship Experience

#### Initial Responsibilities

As with all positive learning experiences, a key factor influencing your success is the ability to communicate effectively. To achieve the most from the clerkship experience, establish your presence with the preceptor and become involved in the clinical environment as quickly as possible. When **you** become involved, those with whom you interact will also become involved. The following tips will assist you in getting the most from your clerkship experience:

1. **Introduce yourself** to the people with whom you'll be working.
2. **Be pleasantly assertive**-remember you are a new member of the team.
3. **Share your goals and interests** with your preceptors and others who may assist in your learning.
4. Determine the **equipment** you will need to interact in this environment--stethoscope, watch, identification card, note pad, resource book, etc.
5. **Dress**--Present yourself as a professional and representative of Loyola University Stritch School of Medicine throughout your clinical experience. You will be expected to wear your white jacket at all times when seeing patients. Wear your nametag and any additional name tags required by some hospitals.
6. **Problems**--Approach your preceptor if you perceive there is a problem. Contact the Education Coordinator if there are irreconcilable differences.
7. **Report Abuse** – Immediately contact the Education Coordinator if you are being subjected to any form of abuse.
8. **Absence**--Make sure you notify the preceptor if you must be absent (not the secretary or receptionist). Preceptors are aware of the absence policy for the clerkship. Let the site coordinator know how to contact you in case of emergency, and always contact the Education Coordinator at aandel@lumc.edu or 708-216-2109

#### Other questions to ask:

1. What are my hours?
2. How do I refer to the preceptor and other staff members? (Dr., Ms., Mrs.)
3. Where do I sit for a break or to chart? For lunch?
4. Where should I hang my coat and store my materials?
5. How should the medical record be used by me for charting purposes?
6. How should I introduce myself to patients? (We recommend that you always introduce yourself as student doctor. Preceptors will be advised not to introduce you as "Dr.\_\_\_\_\_".)
7. How should I see patients--prior to the preceptor, in conjunction with the preceptor, after the preceptor?
8. Where are references located for me to use?
9. May I work with the office staff, nurses, or other partners?

### CLERKSHIP ASSIGNMENTS AND REQUIREMENTS

#### Clinical Responsibilities (45% of final grade)

As previously stated, we expect students to spend a minimum of 30 hours per week in direct ambulatory care. During the clerkship, the students' primary clinical emphasis will be to evaluate ambulatory patients. The expectation is that over the six weeks you will increase your responsibility so that eventually you will be the first person to see patients. After you complete your evaluation, you will review each patient with your preceptor. Additional clinical responsibilities will vary by site. Opportunities to take call, work evening hours, Saturday hours, rounding on inpatients or at the nursing home, are all possible learning venues. You are required to hand in certain documents during your clerkship. **Missing documents will result in a 1-2 point reduction of your final grade.**

## Patient Log Card

The Liaison Committee on Medical Education (LCME), requires that students keep a daily patient log of patient encounters. You will be given a yellow log card at the beginning of the rotation and the log should be kept on hand by students at all times in the clinical setting. **Log entries should be completed by the end of each day and entered into the portal WEEKLY.** Your total number of problems may exceed the number of patients you have seen.

**Assigned** patient means patients in the clinic, (new or returns) that you are sent to interview, present to the attending and write the clinic note on.

**Conditions** are (a) those issues your assigned patients have, i.e., active problems being diagnosed or treated and which you read about. (If your assigned patients have issues that you are not diagnosing, treating or reading about, do not list those issues); (b) issues that other patients on your service have (not assigned to you) that you discuss on rounds and read about; or (c) issues that you encounter by way of simulated patients (simulated patients should not be recorded as "assigned" patients).

The Education Coordinator will check your logs intermittently and contact you if there seems to be a problem with your recording. The Clerkship Director must report any student who fails to keep their logs accurately. **Do NOT wait until the end of the rotation to enter your data into the portal.** **The most common error is forgetting to enter the total number of patients.** Following is an excerpt from a completed log card, an example of the way data is displayed in the portal, and a list of site acronyms.

~ FAMILY MEDICINE ACADEMIC YEAR xxxx-xxxx		
NAME _____		PERIOD _____
SITE _____		
NUMBER OF ASSIGNED PATIENTS		
CONDITION	ENCOUNTERED	SIMULATION
Abdominal Pain/Acute Abdomen	### ### ### ###	
Allergy/Hives Rhinitis	### ### ### ### ###	
Anxiety Disorder	### ### ### ###	
Asthma	### ### ### ###	
Back Pain	### ### ### ###	

PROCEDURES	PREFORMED	OBSERVED	SIMULATION
Arterial Puncture	###	### ###	
Insert Foley	###		
Insert IV Catheter	///		
Insert Lumbar Puncture	### /		
Insert NG Tube	//		
Suture Laceration	//	### ###	
Venipuncture	### ### ### ###		

**Student Log Report By Card**  
**FAMILY MEDICINE CLERKSHIP – Jul6 / Class of xxxx**

Student Name	Diseases Log	Procedures Log
	Card 1	Card 1
Baldly, Goforth	OP-CLPNS	OP-CLPNS
Blindly, Learn	OP-CLPE	OP-CLPE
Boozler, Teri	OP-LUTHNES	OP-LUTHNES
Broken, Iam	OP-WSSAL	OP-WSSAL
Crowing, Stop	OP-CLPP	Missing
Hanky, Mister	OP-BARBA	OP-BARBA
Hahn, Jessica	OP-ALEX	OP-ALEX
Kostner, Bart	OP-HINS	OP-HINS
Kringle, Kris	OP-CLPE	OP-CLPE
Martin, Dean	OP-BARBA	OP-BARBA
Nathan, Jon	OP-RESFPRP	OP-RESFPRP

**Student Log Monitoring**  
**FAMILY MEDICINE CLERKSHIP – Jul6 / Class of xxxx**  
From (Date) To (Date)

Student Name	Site	Assigned Patients
Baldly, Goforth	OP-CLPNS	62
Blindly, Learn	OP-CLPE	131
Boozler, Teri	OP-LUTHNES	60
Broken, Iam	OP-WSSAL	14
Crowing, Stop	OP-CLPP	35
Hanky, Mister	OP-BARBA	216
Hahn, Jessica	OP-ALEX	165
Kostner, Bart	OP-HINS	103
Kringle, Kris	OP-CLPE	153
Martin, Dean	OP-BARBA	155
Nathan, Jon	OP-RESFPRP	167

## Site Acronyms

Clerkship Site / Address	Acronym for SSOM Log Card Database
Alexian Brothers Medical Group	ALEX
Bremen Family Medicine	Bremen FM
Chicago Health Medical Group/Berwyn	CHMG BWN
Cook-Loyola-Provident FPRP - Englewood	CLPE
Cook-Loyola-Provident FPRP Near South	CLP NS
Cook-Loyola-Provident FPRP- Prieto	CLP P
Downers Grove FPC-Hulesch	DRGV
Family Medical Care – Grandinetti & Hennes	GRAN
Gottlieb Family Medicine (Dr. Shivakumar)	GTB
Hinsdale FMRP (including satellites)	HINS FMRP
La Grange FMRP-(including satellites)	LAGR FMRP
Loyola Center for Health at Elmwood Park	LOYEP
Loyola Family Medicine Group @ Gottlieb	LOYFMG
Loyola Maywood FPC (Dr. Ahomka-Lindsay)	LOYFPC
Lutheran General FPRP (including satellites)	LUTH FMRP
MacNeal FPRP (including satellites)	MAC
Marshall County Family FPC – Plymouth, IN	PLYMOUTH FM
PCC Austin Family Health Center	WSPCCA
PCC Lake Street Health Center	WSPCC
PCC Salud Family Health Center	WSSAL
Resurrection FPRP	RES FMRP
Saint Joseph Regional Medical Center	STJOS RMC
Vincent Bartolomeo, M.D.	BARTO
West Suburban Medical Center FMRP	WSUB FMRP

**Contact info:**

Amy Andel – [aandel@luc.edu](mailto:aandel@luc.edu)

## Procedural Checklist and Critical Incidents

During the Family Medicine Clerkship, we expect students to encounter a number of common outpatient procedures. Although each preceptor's office may only perform some of the listed procedures, we expect students to perform or assist in at least 10 of the procedures listed on the Procedural Checklist and Critical Incidents log – found in the pocket of your orientation folder. The teaching of a procedure may be delegated by the preceptor to a non-physician member of the health care team where appropriate, e.g., nurse, laboratory technologist. Please have the procedure supervisor sign-off and indicate yes or no as to your competency with performing the procedure. Keep the checklist with you at all times in the clinical setting. **The procedural checklist is due at your final exam.**

Critical incident recording is an additional way to log your experiences. Much like a diary, it provides a systemic and consistent forum to note particularly important or memorable experiences. **The critical incidents log is due at your final exam.**

**You are required to log a minimum of two entries per week, e.g.:**

### Sample Critical Incidents

Date	Incident
10/21	Observed my preceptor tell Mrs. B.F. she had breast CA. Emotions/ reactions very powerful.
10/22	Placed 3 sutures in a 7 year old with hand laceration. Fun and confidence booster!
10/25	Day in the phlebotomy lab: learned quickly not to count down 3,2,1,...b/c pts. move.
10/27	Drug rep discussion about clinical trials, statistics, etc. Rep had preformed answers to everything, rarely scientific in origin. We have to make our own decisions about meds/procedures/etc.
11/5	Watched a young girl reveal prior abuse-it's amazing how open people are with their doctors.

**Your Procedural Checklist/Critical Incidents Log is located in the pocket of your Orientation folder.**



## **Biopsychosocial Project (7.5% of Final Grade)**

This project is designed to help you appreciate health and illness from a biopsychosocial perspective. In part, the term biopsychosocial implies that peoples' health is inextricably linked to what happens in their every day lives. All too often in our practice of medicine, we gain a very limited, sometimes excessively narrow view of the problems that people are facing. This may result in less than adequate care for our patients. Perhaps you can think of some examples from your own lives: a close friend, a family member, a teacher, someone who has suffered an illness or who has died. What was it like for this person to be sick? What were her/his fears and concerns? What other factors played a role in that person's experience of illness? What impact did family have upon the experience? What impact did this experience have upon the family? What enabled that person to feel supported and get back into the swing of things again? These questions represent some ways in which we hope that this project will help you gain a larger view of what people are actually experiencing when they come to you for help. It is our objective to have you select a patient in your practice and examine that patient and her/his family to consider the following principles of Family Medicine:

1. Viewing peoples' health in relation to their daily lives.
2. Understanding the role of family in caring for patients.
3. Appreciating the inseparability of illness and everyday life.
4. Recognizing the importance of optimizing people's daily function.

In order to accomplish these goals, you will be expected to interview a patient whom you have identified together with your preceptor. Your preceptor will help you choose someone who is open to this. Ideally, it would be done at the same time the patient is in for a visit and the patient can be asked to spend just a little longer. In some cases, the patient may prefer to return on a different day when it is more convenient, or you may conduct your interview via phone. You should try to complete the interview within 45 minutes to an hour. Again, the purpose of the interview is to get a better idea of what your patients' lives are all about, what their families are like, what problems they may be facing, to whom they turn for support, and how this relates to their health in general. Inquire if your preceptor would like a copy of your write-up for the patient's chart. We expect you to use the following strategies:

1. **Clinical summary of present illness.** In one paragraph, briefly describe what's going on with your patient. Mention her/his chief complaint and then discuss the primary aspects of your patient's illness, including pertinent information from Past Medical History, Family History, Social History, etc.
2. **Three-generation genogram.** (See “Working with Families,” Article on FM Lumen site for a guide to constructing the genogram.) Focus on structural and functional relationships (conflict, affiliation, abuse, separation, etc.) within the family. Also, be sure to identify and label medical problems within the family. A good way to begin this segment is by saying, “I'd like to learn a little more about your family so that I can draw your family tree. This will help me understand more about you and your health.”
3. **Family and occupational assessment**  
This is an opportunity for you to learn how your patient gets along with family members and co-workers. Ask your patient to complete the Family System APGAR and Work System APGAR, when applicable, which appear later in this section. **This must be included with your written project.**
4. **Stressors and resources**  
In addition to the problems that patients present to you, there often exist other challenges that they are facing. These challenges can be viewed as stressors. Stressors may be positive (getting married, receiving a promotion, buying a new house, graduating from school, etc.) or negative (losing a loved one to death, learning about having cancer, sustaining a broken leg, being fired from a job, having service cut off by the electric company, etc.). One way of learning more about peoples' stressors is to ask, “What concerns do you have about your life right now?” or “What else is on your mind that's been troubling you?” You may encounter resistance when you ask these questions. If so, it might help to

say, "Learning more about your concerns gives me a better idea of what your life is all about. In that way, your doctor and I can take better care of you."

In order to respond to these various stressors, people need help. Help can come in a variety of ways. These are called resources. Examples of resources include money, physical health, neighbors, community agencies, transportation, etc. Usually, the most important resources that people have to buffer the impact of stressors are family and friends. One way of learning about personal support is by asking, "Who is the most important person in your life you can turn to for help or to talk to about your feelings?"

Asking, "What else has made it easier for you to cope with everything that you are going through?" may enable you to further assess peoples' resources. You may also want to learn more about peoples' religious and spiritual beliefs, their hobbies, and things that they do for fun.

One way of remembering potential sources of distress and support is the following acronym, SCREEEM:

S	Social
C	Cultural
R	Religious
E	Educational
E	Environmental
E	Economic
M	Medical

#### 5. **Patient's perspective of illness**

Often, when people come to us for help, they have a number of underlying, related concerns. Unfortunately, patients are rarely able to bring these concerns to our attention. Reasons for this include lack of time, fear of appearing foolish and physician disinterest. Perhaps, one of the biggest reasons is that physicians fail to listen to their patients. It is easy to see how this can happen. We are preoccupied with making an accurate diagnosis, determining appropriate treatment, and getting on to see the next patient. As a result of this preoccupation, we tend to miss clues that patients give us about what is really on their minds. When this happens, even though we may have prescribed the appropriate medicines and ordered the necessary tests, we run the risk of leaving our patients still feeling anxious and uncertain about their condition. In order to reduce peoples' anxiety, it is important to explore their feelings and concerns and to identify what worries them the most. This will give them a chance to share what may really be on their mind. The following questions will help you solicit this information:

"What worries you the most about what's happening to you right now?"

"It's important for me to know what's been on your mind about this."

"What do you expect your doctor to do for you about this problem?"

Once you receive this information, you may feel overwhelmed by some of the emotions that people may express. Remember one important principle: You do not have to fix peoples' feelings. Instead, **listen**. Then, **put yourself in their shoes for a moment** and **respond to what they have to say**. For example, when Ms. Chiles tearfully says to you, "I was just hoping that I didn't have cancer. My sister died three years ago from lymphoma in her bowel." You can respond by remaining silent, holding her hand, allowing her to cry, and then saying, "It seems like you're feeling a lot of pain about your sister." Showing people empathy proves that their feelings are important to you and that you care. This builds their trust and gives them confidence in you as their doctor.

#### 6. **Assessment**

Using all of the information you have now obtained, list and describe your evaluation of your patient, both "medically" and "psychosocially." Be sure to explain how the concerns that you have identified relate to your patient's primary medical problems and impact upon her/his health care.

#### 7. **Plan**

State your treatment recommendations for each problem and concern identified in your assessment.

8. **Feedback**

Now that you have had this opportunity to more extensively evaluate your patient from this biopsychosocial perspective, please answer the following questions:

1. What has this project meant to you?
2. What have you learned from this assignment that you may not have learned otherwise?

9. **Presentation to Class**

You will present your patient back at Loyola to one-third of the students currently doing the Family Medicine Clerkship. You will have about 10 minutes to present the patient's history, genogram, APGARS, your assessment, etc. and then there will be 10 minutes for group discussion. **Come prepared with a hard copy of your project including the genogram and APGAR table(s). Failure to present due to an error on your part (e.g. forgetting to come at designated time) will result in two points automatically deducted from the total grade for the assignment.**

**BIOPSYCHOSOCIAL PROJECT OUTLINE**  
**Family Medicine Clerkship**

1. Clinical data of present illness
  
  
  
  
  
  
  
  
  
  
  
  
  
  
  
  
  
  
  
  
  
2. Three-generation genogram (see example on prior page)
  
  
  
  
  
  
  
  
  
  
  
  
  
  
  
  
  
  
  
  
  
3. Family and occupational assessment (Family and Work System APGARS - see next two pages)
  
  
  
  
  
  
  
  
  
  
  
  
  
  
  
  
  
  
  
  
  
4. Stressors and resources
  
  
  
  
  
  
  
  
  
  
  
  
  
  
  
  
  
  
  
  
  
5. Patient's perspective of illness
  
  
  
  
  
  
  
  
  
  
  
  
  
  
  
  
  
  
  
  
6. Assessment
  
  
  
  
  
  
  
  
  
  
  
  
  
  
  
  
  
  
  
  
7. Plan
  
  
  
  
  
  
  
  
  
  
  
  
  
  
  
  
  
  
  
  
8. Feedback

## SMILKSTEIN'S FAMILY SYSTEM APGAR ITEMS

	Almost Always	Some of the Time	Hardly Ever
1) I am satisfied that I can turn to my family for help when something is troubling me.			
2) I am satisfied with the way my family talks over things with me and shares problems with me.			
3) I am satisfied that my family accepts and supports my wishes to take on new activities or directions.			
4) I am satisfied with the way my family expresses affection and responds to my emotions, such as anger, sorrow, and love.			
5) I am satisfied with the way my family and I share time together.			

**Rating Scale:**

Almost Always = 2 pts.  
 Some of the Time = 1 pt.  
 Hardly Ever = 0 pts.

**Scoring:**

8-10 = Highly Functional  
 4-7 = Moderately Dysfunctional  
 0-3 = Dysfunctional

**Example:**

Total = 7 pts.  
 Moderately Dysfunctional

## SMILKSTEIN'S WORK SYSTEM APGAR ITEMS

	Almost Always	Some of the Time	Hardly Ever
1) I am satisfied that I can turn to a fellow worker for help when something is troubling me.			
2) I am satisfied with the way my fellow workers talk over things with me and share problems with me.			
3) I am satisfied that my fellow workers accept and support my ideas or thoughts.			
4) I am satisfied with the way my fellow workers respond to my emotions, such as anger, sorrow, or laughter.			
5) I am satisfied with the way my fellow workers and I share time together.			
6) I am satisfied with the way I get along with the person who is my closest or immediate supervisor.			
7) I am satisfied with the work I do at my place of employment.			

**Rating Scale:**

Almost Always = 2 pts.  
 Some of the Time = 1 pt.  
 Hardly Ever = 0 pts.

**Scoring:**

11-14 = Highly Functional  
 5-10 = Moderately Dysfunctional  
 0-4 = Dysfunctional

**Example:**

Total = 7 pts.  
 Moderately Dysfunctional

## SAMPLE BIOPSYCHOSOCIAL PROJECT

(Actual project completed by a Loyola Student. **Please note: the APGAR Tables are not included in this example, however they are required to be included with your written project.**

### Clinical data of present illness

Mrs. C is a 55-year old African American clinic receptionist with a history of hypothyroidism, hypertension, oropharyngeal carcinoma s/p chemo and radiotherapy (1997), uterine fibroids s/p hysterectomy (2008), cholecystectomy (2004) and gastritis (1997) now presenting to follow-up on left foot pain and swelling that began with gradual onset a year ago. Mrs. C described her foot pain as a dull ache on the bottom of her feet and ankle of 3/10 severity, worsened by long periods of standing. She had tried to take ibuprofen for the pain, with minimal relief. Worsening pain drove her to present to the clinic several months ago and she was given a referral to physical therapy. She just recently completed 4 weeks of sessions that occurred twice per week, and now reports that her pain has completely resolved. She is now walking 2 miles daily for exercise without any pain.

Today, she also says that she has noticed her hair thinning for the past month on the top of her scalp. She has not noticed clumps of hair falling out. She denies recently making drastic dietary changes, taking new medications, using new hair products, or being more stressed out than usual.

She also notes feeling continued bloating and halitosis, which have been chronic since she developed gastritis from her cancer treatment in the 90s. Her reflux symptoms are otherwise well controlled, and on the occasion that she does experience heartburn, it resolves with Prevacid 30 mg PRN. She was recently given a GI referral, saw a gastroenterologist at West Sub, and is currently waiting for the results of an H. Pylori test. She has had, three past H. Pylori tests – one in 1997 that was positive, one in 2010 that was positive and one in 2006 that was negative. She was treated with antibiotics in the past. She had a routine colonoscopy 5 years ago that was normal.

She also has noticed a small skin tag that developed in her left axilla that she would like removed for cosmetic reasons. She denies any pain, drainage or erythema at the site of the lesion. She has had similar lesions before that have been removed.

Mrs. C is taking Synthroid 125 mcg daily for her hypothyroidism. Her TSH is monitored regularly and is well controlled. She takes 10-12.5 mg of Lisinopril-HCTZ daily for her hypertension (diagnosed in 2003), which has also been well controlled. She is not taking any other medications aside from Prevacid 30 mg as needed for heartburn. Mrs. S notes that her family history is significant for several siblings with diabetes, heart disease and hypertension. Her mother died from complications of diabetes at the age of 72, and her father died of an MI at the age of 80. She has no known allergies. She denies any history of tobacco, illicit drug use, or alcohol abuse. She lives at home with her husband of 24 years, her 22 y/o twin daughters and 24 y/o son who will soon be leaving for college.

On physical exam, Mrs. C was pleasant, talkative and not in any acute distress. Her vital signs were stable and within the normal range (T: 98.3 F, P: 80, RR: 20, B/P 120/80). Some thinning of the hair on the vertex of her scalp was noted, without any obvious bald spots. No rashes, lesions or scarring were otherwise noted on her scalp. There was no hirsutism. Her thyroid size was within normal limits and without palpable masses or lesions. Her lungs were clear to auscultation bilaterally. Normal S1 and S2 heart sounds were auscultated without murmurs, rubs or gallops. Her abdominal exam was normal, without hepatosplenomegaly or tenderness to light or deep palpation. Normoactive bowel sounds were auscultated in all four quadrants. A nontender 3 mm pedunculated skin lesion was noted in the left axilla, without erythema, purulent drainage or hyperpigmentation. She had full strength and range of motion in both ankles, and lower extremity edema was absent. Pedal pulses were 2+ and equal bilaterally. She denied any tenderness to palpation or pain during movement of either foot. The results of her H. Pylori test were still pending.

### Three generation genogram

See attached

### Family and occupational assessment

Family System APGAR Score = 7 (Moderately dysfunctional)

Work System APGAR Score = 4 (Dysfunctional)

## Stressors

### **1. Family**

Although Mrs. C loves her family, they are currently her most significant source of stress. She has five adult children and five grandchildren. Currently, her 22-year-old twin daughters and 24-year old son still live at home with her and her husband of 24 years. Mrs. C is a tidy person who likes to keep things organized. Her children often frustrate her when they leave messes around the house and expect her to constantly clean up after them. She also becomes irritated when she arrives home after a long day of work longing for her personal space and solitude, only to cook and clean for her children. When Mrs. C reminds them that they are old enough to take responsibility for themselves, pick up around the house and generally be more independent, she finds that it goes "in one ear and out the other." When she looks to her husband for support in communicating her frustration to her children, he constantly takes their side and fears disciplining them. Thus, Mrs. C always feels like the "bad guy" for having to serve as the sole disciplinarian. Furthermore, Mrs. C feels that her husband often unfairly directs anger toward her when there are conflicts with the children. Mrs. C attributes the beginnings of this dysfunctional dynamic to her development of oropharyngeal cancer in the 1990's. During that time, she was extremely weak and nauseous due to the intense chemotherapy and radiation treatment she underwent. Her children were too young to understand her illness, and often became afraid and uncomfortable when they witnessed her vomiting. She felt that this drove her children away from her and toward her husband. Her husband, emotionally preparing himself to take the children back to Puerto Rico and care for them himself if she succumbed to cancer, encouraged the children's dependence on him. She worries that the stress from family conflict negatively affects her health, specifically that it raises her blood pressure.

### **2. Work**

Mrs. C has worked as a clinic receptionist at a family medicine clinic for 16 years. Although there are reasons that she loves her job, she finds the social aspects of her workplace environment generally stressful. She often feels that her female co-workers frequently gossip about others and are untrustworthy. She also has sensed jealousy from other co-workers, who resent her for her constant positive attitude and special bond with many of the patients that come into clinic. Mrs. C is also an efficient, fast worker and often has to pick up the slack of one of her co-workers, who works very slowly. It frustrates her that this particular co-worker doesn't seem to have the same passion for people and enjoyment of her work in which Mrs. C takes special pride.

### **3. Health/Weight**

Mrs. C's chronic problems such as hypertension and hypothyroidism are currently well controlled, and although the hair thinning, skin tag and bloating/halitosis have been irritating, she doesn't currently have any acute health complaints that are severely distressing. However, her health has been a significant source of stress in the past. Most recently, her chronic left foot pain affected her daily functioning and generally bright, positive personality. She noticed herself taking on the sick role, being more sedentary and generally "shutting down." She talked less, and had less desire to interact with others. Now that her foot pain has completely resolved, she feels she is back to normal. She also has a chronic, mild level of stress due to her obesity. She knows how important it is to lower her risk of diabetes and MI given her significant family history, yet finds the necessary lifestyle changes daunting. She has tried to increase the amount of walking she does, and would like to start jogging in order to lose weight, but she worries the foot pain may return. She has had several failed attempts to diet in the past. Although she has recently increased her intake of fruits and vegetables and reduced her intake of fried, fatty foods, she fears she is actually continuing to gain weight as she ages. She cites that her biggest challenge is the cultural and symbolic importance of food in her family.

## Resources

### **1. Religion/Faith**

Mrs. C is a proud member of an Episcopal church on Chicago's west side. She has sang in the choir since 1999 and is heavily involved in the church community. Mrs. C calls on her support system through church and her faith in God to help her survive difficult times. She believes that her faith gave her the strength to overcome cancer. Having a strong faith has allowed her to develop a sound perspective on life's highs and lows and the necessary



coping skills to deal with challenges, including those related to her health. Despite her stressful workplace environment, Mrs. C loves her job because it allows her the opportunity to share her ministry. When she sees that a patient in the clinic has just received a devastating diagnosis or has recently lost a loved one, she takes them into the hallway, hugs them and shares with them the story about how her faith gave her the strength to survive cancer. The patients respond positively to her message and develop a strong bond with her. Mrs. C says the "feeling of being needed" gives her a sense of satisfaction and purpose.

## **2. Family**

Although Mrs. C's family dynamic can cause her stress, her husband and children are also her main source of social support. She is also extremely proud of her 5 children, and her 5 grandchildren bring her joy. Although three of her children live in the home, all five have jobs. She has a loving relationship with her husband of 24 years, who supported her faithfully and worked two jobs to make ends meet during her cancer treatment.

## **2. Finances**

Mrs. C says although she doesn't consider herself "rich," she and her husband have well-paying jobs and feel financially comfortable. They are able to pay bills and afford some luxuries in addition to the necessities. She feels blessed that her financial situation is not a source of stress.

## **3. Interests/Hobbies**

Mrs. C loves singing in the choir. She has performed all over the Chicago area and has been featured on several CDs. She has close bonds with the rest of the members of the choir and experiences intense joy through worshipping with song. She also loves shopping in thrift stores. Every Saturday morning, she will go to a specific thrift store on the North side of Chicago to browse the racks, finding treasures and socializing with the other frequenters of the store. She considers these trips to the thrift store her "me" time, where she can relax and focus on something that makes her happy.

## **4. Dr. L**

Mrs. C has a close patient-physician relationship with Dr. L, and feels confident in the care she receives at the clinic. Most recently, Dr. L helped Mrs. C to resolve her foot pain by referring her to physical therapy. Dr. L will continue to serve as a resource for Mrs. C's health needs as they arise.

### **Patient's Perspective of Illness**

As someone who has experienced serious life-threatening illness in the past (oropharyngeal cancer), Mrs. C is relatively content with the current state of her health. Although some of her issues today are mildly bothersome, she generally feels well. She is thrilled that the foot pain is resolved, and has been able to exercise regularly by walking 2 miles a day. She would like to begin jogging in order to lose weight now that she no longer has foot pain, but is concerned that the pain may return due to the impact on her joints. She also would like to be reassured that the hair loss is not something she needs to worry about. The chronic bloating and halitosis have been more irritating than concerning for Mrs. C. She feels that she has a solid understanding of her chronic conditions such as hypertension and hypothyroidism thanks to Dr. L, and takes her medications for these conditions compliantly. She does worry about her obesity given that diabetes and heart disease have been so prevalent in her family, and would like to work on healthy lifestyle change. She has already begun to increase her intake of fruits and vegetables and reduce her intake of fried, fatty foods, but she is not entirely confident that she can commit to making more drastic changes at this time.

### **Assessment and Plan**

- 1. Left Foot pain and swelling:** Mrs. C's left foot and ankle pain were likely due to osteoarthritis. She reports at this visit that it has completely resolved after the 8 physical therapy sessions she attended over a 4-week period. She continues to perform strength exercises at home and understands the importance of RICE (rest, ice, compress, elevate) in the event of a future injury or return of pain. She has been walking two miles daily and would like to start jogging. Mrs. C was encouraged to purchase appropriate running shoes if she plans to jog. She was educated that an elliptical or swimming are better options, as they will generate less impact on her joints.

2. **Non-scarring alopecia:** The differential for non-scarring alopecia includes anagen effluvium, androgenetic alopecia, chemical alopecia, mild folliculitis, inherited disorders of the hair shaft, telogen effluvium, alopecia areata and traumatic alopecia. Mrs. C's history was negative for new medications or hair products, recent stressful life events or dietary changes. On exam, some mild, diffuse thinning of the hair was noted on the vertex of her scalp but there were no obvious bald spots and no scars. Her alopecia had a gradual onset and insidious course around the time of menopause. These characteristics best fit the picture of androgenetic alopecia, although Mrs. C's physical exam was negative for any other signs of virilization such as acne or hirsutism. Mrs. C's TSH was rechecked today to rule out hypothyroidism as a cause for her hair loss and to ensure that her hypothyroidism continues to be well controlled on Synthroid. Mrs. C was counseled to avoid the use of hair treatments and tonics, as they may worsen her alopecia. Given that Mrs. C has no other signs of androgen excess or nutritional deficiency, no additional labs will be ordered at this time to further evaluate her alopecia.
3. **Bloating/Gastritis:** Although pain from heartburn is well controlled on Prevacid, bloating has been a chronic problem for Mrs. C since her chemotherapy treatments in the late 90's and has recently been worsened since she increased her intake of fiber in an effort to eat healthier. Mrs. C just recently saw a gastroenterologist and the results of her most recent H. Pylori test are still pending. Mrs. C was encouraged to try over the counter Beeno after eating vegetables to see if it reduces her bloating. She was also encouraged to continue taking her Prevacid as needed for heartburn. She will be informed of the results of her H. Pylori test when they become available. If the results are positive, we can treat her with the appropriate antibiotic regimen.
4. **Acrochordon in the left axilla:** The small pedunculated, non-tender, non-irritated skin lesion Mrs. C wished to have cosmetically removed was noted on physical exam. Its location in the axilla (an area of friction) and appearance were consistent with the diagnosis of acrochordon. Mrs. C's acrochordon was excised today for cosmetic reasons. She was counseled on appropriate wound care.
5. **Hypothyroidism:** Mrs. C's last TSH level was checked in January of this year and was within normal limits (3.55) at that time. As mentioned earlier, Mrs. TSH was rechecked today to ensure that her hypothyroidism continues to be well controlled with Synthroid 125 mcg PO daily. She was prescribed a refill and encouraged to continue taking her medications as directed.
6. **Hypertension:** Mrs. C's blood pressure was 120/80 today. Her hypertension is well controlled on Lisinopril-HCTZ 10-12.5 MG tabs PO daily. She was encouraged to continue taking her medications as directed.
7. **Obesity:** Mrs. C's BMI today was 36, categorizing her as obese. Over the past few months, she has tried to make dietary changes including increasing fiber in her diet through fruits and vegetables and decreasing fried/fatty foods. She has also increased her walking to 2 miles per day. However, she has not yet seen any changes in her weight and fears she is unable to make more stringent changes to her diet. The biggest challenge for her in making the necessary lifestyle changes for significant weight loss is the cultural and symbolic importance of food in her family. Mrs. C diet was reviewed today. She was further educated on diet and exercise and her questions were answered. She was encouraged to set two tangible goals to follow-up on at her next visit. She will substitute her evening snack of 5 taquitos with healthier options such as a banana with 1 tablespoon of peanut butter. She will also replace her 1 sugary soda/day with Crystal Light. She was also encouraged to inform her family of her goals and garner their support her in accomplishing them.
8. **Family and work stressors:** While Mrs. C loves her family and reports general satisfaction with her work, she does report social conflicts in both contexts. She is consistently stressed about being seen as the "bad guy" by her adult children who live at home when she disciplines them, especially because her husband does not support her in communicating the same message of wanting them to take more responsibility for themselves. She is troubled by the feeling that her husband may have a closer relationship with his children because he refuses to discipline them and because of the residual effects of her cancer on her family dynamic. Although work brings her a great deal of joy by allowing her the opportunity to share her faith with

patients in difficult situations, dealing with her untrustworthy and gossiping coworkers frustrates her. Mrs. C believes that her blood pressure rises in response to these social stressors. Mrs. C was counseled today to schedule a time to discuss her frustrations openly with her family in a comfortable setting, instead of waiting until she has lost her temper and cannot express her feelings calmly and rationally. If the non-confrontational family discussion does not lead to an improvement in the dysfunctional family dynamic, Mrs. C may should follow-up with behavioral health at our clinic to develop healthy coping mechanisms to manage stress from conflicts with her children.

9. **Health Maintenance:** Mrs. C is due for a mammogram, as her last mammogram was in September of 2011 and was read as a category BIRAD2. She was given a referral for her next mammogram today. A lipid panel was also drawn today. She is up to date on her colonoscopy screening (which was performed 5 years ago and was normal) and diabetes screening (which was performed in January of 2012 and was negative for diabetes). She does not need a pap smear as she has had a full hysterectomy.

### Feedback

This project has truly demonstrated to me the therapeutic power of understanding a patient in his or her full biopsychosocial context. For instance, by understanding Mrs. C's worldview and specific stressors and resources, I was able tailor my counseling on diet and exercise to her specific needs. In addition, the rapport I established through gathering that information rendered my advice more meaningful to her. Learning of Mrs. C's history of cancer and the integral role her faith played in coping with the traumatic experience of illness allowed me to better understand her perspective on her current medical problems, and would allow me to accurately predict what her response might be to future health issues. If Mrs. C was to be diagnosed with cancer or some other acutely life-threatening condition, I would know to emphasize the importance of maintaining her ties to the church community and continuing to practice her faith, as these strategies have been effective in the past.

What I have gained from this project is a new awareness of the interdependence of physical, emotional, psychological and social health. It has driven home the point that to emphasize only the medical or physical aspects of a human being during a patient encounter is shortsighted. My goal as a third year medical student is not only to develop my style as a clinician, but as a healer. Emphasizing the psychological and social aspects of patients will not only allow me to establish rapport, but will allow me to truly treat them as unique individuals. I can tailor my advice to meet their specific situations. I can more effectively explain their health conditions through understanding their worldview and previous experience with and response to illness. I can more effectively engage their families by understanding the relationships and dynamics that comprise them. All of these abilities are no less important than effectively understanding objective laboratory data or physical exam findings. In fact, I find that these abilities are what comprise the "art" of medicine.

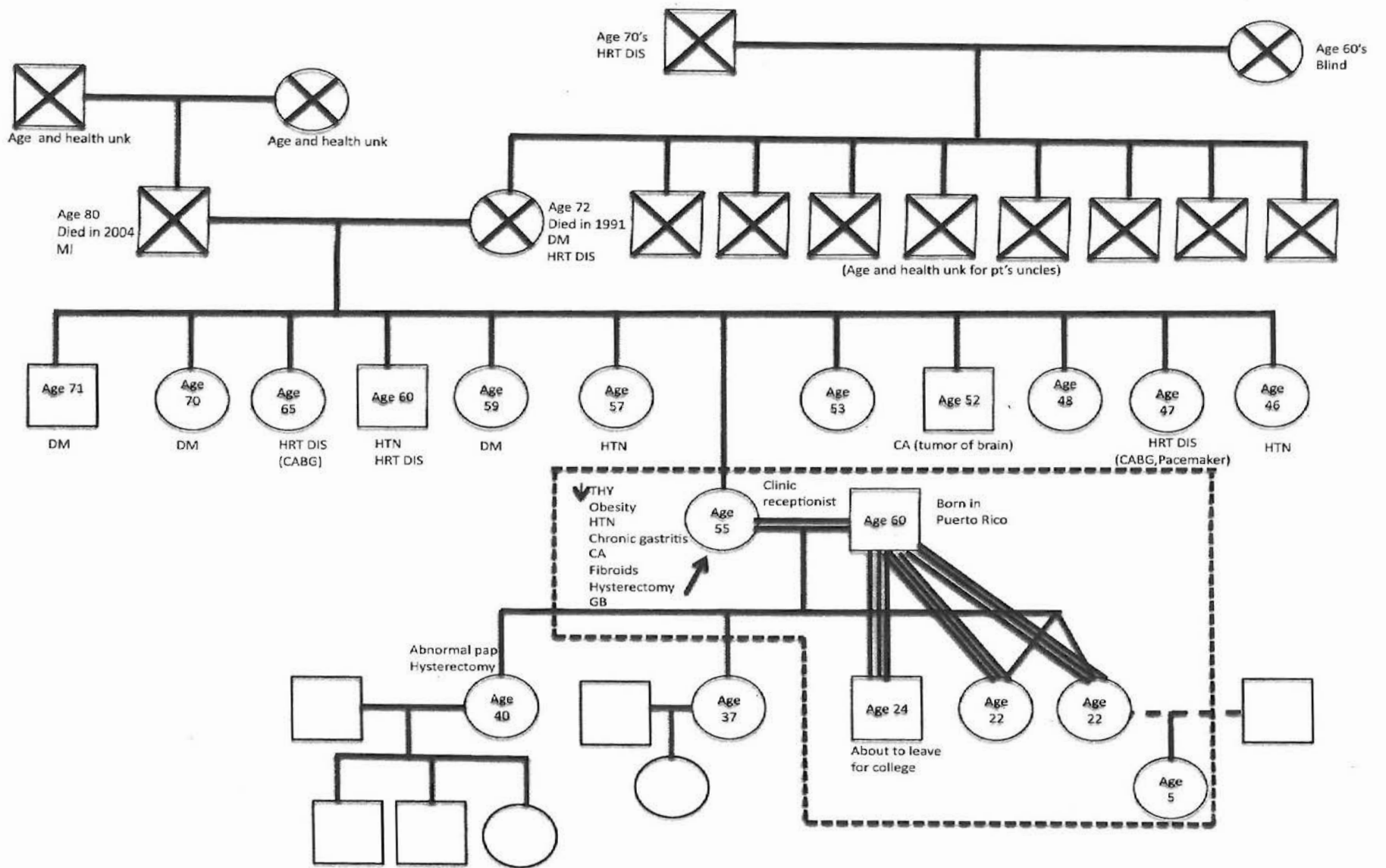



## Evidence-Based Medicine (EBM) Project (7.5% of Final Grade)

This exercise is designed to provide you with experience in applying the results of medical research to clinical practice, i.e., to help you provide care for your patient that is based on the best evidence available. This is known as Evidence-Based medicine. You will continue to utilize Evidence-Based Medicine throughout your medical career.

The project is based on the articles located on the Family Medicine LUMEN website, “Users' Guides to the Medical Literature” created by the Evidence-Based Working Group from McMaster University. Carefully reading these articles will provide you with the tools you need to complete the assignment. You need to start thinking of a clinical question about one of your patients early in your clerkship. Define a question related to therapy or prevention, a diagnostic test, or the harmfulness of an intervention or treatment. If you choose to answer a different type of clinical question, or use a type of study other than the ones described in these articles, you will need to review additional guides available from the library. **Please be sure to apply the appropriate guides to answer the questions in the assignment.** If you do not use the appropriate guides, you will not receive full credit. **If you need additional help, be sure to contact one of the Information Services Librarians at [hsl@luc.edu](mailto:hsl@luc.edu) or 708-216-9192.**

Your clinical question should have three parts: 1) the patient; 2) the intervention; and 3) the outcome of interest. The patient refers to the type of patient/condition (for example, an adult postmenopausal female). The intervention refers to the test/treatment/preventive strategy of interest (for example, hormone replacement therapy). The outcome of interest refers to the medical outcome, such as improvement/cure or worsening of a condition or death. Your question should be as specific as possible without being too restrictive. For example: *How effective is hormone replacement therapy in a postmenopausal Caucasian woman in preventing hip fractures?*

Once you identify one or more questions, discuss them with your preceptor to determine the best one to “answer.” Then, follow these steps for the respective type of question. The first step is to do a literature search to identify the most helpful article. This search should be based on the principles you learned in the EBM handout distributed at the start of the school year. Based on that article, you will need to answer the following questions: 1) Are the results of the study valid? 2) What are the results? And 3) Will the results help me in caring for my patients? If the answer to question #1 is “no,” try to find a better alternative paper, if available. If not available, you can use that article, pointing out the weaknesses of the study, and go ahead and answer the remaining questions.

### **Additional Requirement:**

The Health Sciences Library worked with Dr. Levin to create an online module for the library portion of the Evidence-Based Medicine project. You will receive credit for the library portion of the Evidence-Based Medicine project upon completion.

You can access the Library Module for the Evidence-Based Medicine Project via UVID and password at: [http://archer.luhs.org/login?url=http://library.luhs.org/hslibrary/training\\_and\\_education/FamMedClrkshp-LibraryMod/story\\_html5.html](http://archer.luhs.org/login?url=http://library.luhs.org/hslibrary/training_and_education/FamMedClrkshp-LibraryMod/story_html5.html) .

The module is optimized for mobile devices.

Please upload the completed assignment (MS Word document) here:

[http://library.luhs.org/hslibrary/resources\\_for/fam-med01.html](http://library.luhs.org/hslibrary/resources_for/fam-med01.html) Or email the document to [hsl@luc.edu](mailto:hsl@luc.edu).

Library faculty will confirm the module is complete, review your assignment, and provide feedback within 14 business days of the receipt.

Questions: Elizabeth Huggins, Information Services & Instruction Librarian, ehuggins@luc.edu or 708-216-5305

Use the outline on the following page to write up your assignment. Don't forget to attach your original article. An Internet printout can be used **only** if it **clearly** displays all tables and figures.

**HAND IN THIS PROJECT AT YOUR CLERKSHIP EXAM**

## **Evidence-Based Medicine Resources**

### **Online Tutorials –**

Online tutorials provide easy access to practical instruction and tools to help a student learn about topics of interest. This sampling of free evidence-based medicine tutorials provides valuable info that addresses developing clinical questions, evaluating evidence, and performing efficient literature searches.

**Duke University Medical Center Library and University of North Carolina-Chapel Hill Health Sciences Library: Introduction to Evidence-Based Medicine** -- This site provides assistance in developing clinical questions, performing literature searches, evaluating evidence and testing knowledge. Each topic is broken down to help the beginner become proficient in EBM. <http://guides.mclibrary.duke.edu/ebmtutorial>

**Michigan State University, College of Human Medicine, Department of Family Practice: An Introduction to Information Mastery** -- This online course was developed by family physician, Dr. Mark Ebell. It consists of modules designed to help you learn how to read and apply articles about diagnosis, therapy and prognosis; know the steps in performing a meta-analysis; and understand when it is appropriate to perform a decision analysis. Each module contains goals and tools, topic-specific curriculum and a quiz. <http://ndafp.org/image/cache/23s.pdf>

**University of Illinois-Chicago, Library of Health Sciences-Peoria: Evidence-Based Medicine: Finding the Best Clinical Literature** -- Designed to assist health care professionals and students become effective and efficient users of the medical literature, this site helps with such things as formulating patient-centered questions, applying clinical search filters and using MEDLINE-key aspects in developing your EBM skills. <https://researchguides.uic.edu/ebm>

# EVIDENCE-BASED MEDICINE PROJECT OUTLINE

1. **Background:** Your patient's history, physical exam, and issues.
2. **Question/Type:** State the clinically relevant question, and indicate the type of question addressed by the article (therapy, diagnosis, prognosis, etc.)
3. **Literature Search:**  
(Attach a copy of your article – **do not use an Internet printout unless it clearly shows all tables and figures**)  
  
**REMINDER:**  
Complete the Library Module for the Evidence-Based Medicine Project
4. **Study Validity/Results:** From the "User's Guides," apply the appropriate one to briefly critique the article.
5. **Conclusion:** How has your question been answered, if not, why not?
6. **Communication:** How will you communicate study results to your patient and confirm their understanding?

**Turn in your EBM project at the final exam**



## **SAMPLE PROJECT**

### **The efficacy of antibiotics in ameliorating symptoms of acute otitis media in very young children**

#### **1. Background Data (Medical Context for Question)**

During my Family Medicine rotation, I found that one of the most common reasons for children to visit their Family Medicine physician was for generalized illness with earache. The children's caretakers (usually their mother) would often request antibiotics – sometimes, even before they stated that they believed their child had an ear infection.

We spent much of our time in clinic trying to help parents understand that their child would get well without antibiotics. Although most of the children we saw with acute otitis media were five- to seven-year-olds, A.W. was a 22-month-old toddler. Ms. W. brought him to clinic because he had been irritable and more 'clingy' than usual over the past few days, had been eating less, and the evening before had started to run a temperature for which he received baby Tylenol. His sister had recently recovered from a head cold, and Ms. W. suspected that A.W. might have contracted his sister's illness.

On physical exam, A.W. was a shy, well-nourished boy who insisted on remaining with his mother and cried throughout the attempt to examine him. With friendly yet firm persistence by the physician and Ms. W.'s cooperation, the physical exam was completed. Though slightly warm to the touch and with reddened cheeks that could have been from crying, A.W. was afebrile. His eyes were without discharge. His pupils were equal and reactive to light, and extra-ocular eye movements were intact. The nostrils were congested with nasal discharge. The right eardrum appeared normal, and the tympanic membrane was opaque with a normal cone of light. The left tympanic membrane was slightly erythematous and bulged outward, with no discharge or other abnormality noted in the ear canal. A.W. strongly resisted exam of both ears. While crying, his erythematous posterior pharynx was seen. Mucous membranes were moist. A.W.'s lungs were difficult to hear due to crying, but there was good air movement. Heart was regular rate and rhythm. Abdomen was soft, non-tender and non-distended. Pulses and strength in the extremities were normal.

A.W. was sent home without antibiotics, with instructions for his mother regarding symptomatic relief and hydration. A.W.'s case caused me to remember the story my parents often tell of the time I had a painful ear infection as a toddler. According to my parents, I was treated with 'some kind of antibiotics.' I began to think about how we had not given antibiotics to A.W. while I had received them when I was nearly the same age so long ago. As a result, I framed the clinical question below.

#### **2. Clinical Question**

My question is of the therapy/prevention type. It is as follows:

What is the efficacy of antibiotics in ameliorating symptoms of acute otitis media in very young children?

### 3. List the articles identified in the literature search and the one I used.

Please see attached list of articles. The article I used is number 15 on the list. It is entitled:

Primary care based randomised, double blind trial of amoxicillin versus placebo for acute otitis media in children aged under 2 years. *British Medical Journal*, February 5, 2000, Vol 320 No. 7231, 350-4.

### 4. Are the results of the study valid?

(Discuss using primary / secondary guides.)

*Primary Guides:*

#### Was the assignment of patients to treatment/prevention randomized?

The study was performed in the Netherlands on children aged between six and 24 months who presented to their general practitioner with acute otitis media between 1996 and 1998.

After parental consent was obtained during the first visit, the assignment of patients to treatment was randomized using computerized two-block randomization. Access to the allocation schedule was possible only from the pharmacy of the University Medical Centre in Utrecht. The schedule was protected by computerized code and accessed only if severe complications or side effects occurred in a patient.

The study randomized patients between two arms: treatment with amoxicillin suspension, 40 mg/kg, three times daily for 10 days, or an identical-appearing placebo suspension.

#### Were all the patients who entered the trial properly accounted for and attributed at its conclusion?

#### Was follow-up complete?

All patients were properly accounted for and attributed, even though 12 (five percent of the study population) were lost to follow-up over the six weeks of the study. This is presented very clearly in a figure labeled "Trial profile and participant flow" in the paper, and is discussed in the results section as well. Of a total of 240 patients, 117 received amoxicillin and 123 received placebo. Fifteen of the patients (four who were supposed to receive amoxicillin and 11 who were supposed to receive placebo) were allocated as having failed treatment because they took other antibiotics instead. One of the patients receiving placebo was admitted to the hospital due to worsening symptoms. Twelve patients (six each receiving amoxicillin and placebo) were lost to follow-up. The number of patients with the full 42 days' worth of data for the trial was 107 in the amoxicillin group and 105 in the placebo group.

#### Were patients analyzed in the groups to which they were randomized?

Yes. The investigators checked the robustness of their conclusion that amoxicillin did not significantly impact the clinical course of acute otitis media. They constructed a 'best case' scenario, in which those with incomplete data in the group receiving amoxicillin were assumed to be cured and the incomplete cases in the placebo group were not cured. The analysis did not change the study results.

### Secondary Guides

Were patients, health workers, and study personnel ‘blind’ to treatment/prevention?

Yes. The paper states that the amoxicillin suspension and the placebo suspension looked and tasted the same. The authors also state that “doctors, parents, and investigators remained blinded throughout the study” (p. 351).

Were the groups similar at the start of the trial?

Yes. Table 1 in the paper, titled “Baseline characteristics of 240 children randomised in trial of antibiotic use for treatment of acute otitis media” (p. 352), shows the number of children in each treatment arm that have various characteristics. I have calculated the percentage of each group belonging to each category in the two tables below. The first table shows the categories in which the two groups are most similar.

	Percent of Patients in Group	
	Amoxicillin	Placebo
Male Patients	55%	54%
Breastfed for over six months	18%	18%
Presented between October and March	65%	64%
Symptoms:		
Earache	70%	67%
Fever	68%	65%
Perforated ear drum	15%	17%
Bilateral acute otitis media	64%	62%
Bulging ear drum	22%	24%

Mean age of 13.3 months is identical for both groups.

Differences between the groups of more than three percentage points are in the categories presented below.

	Percent of Patients in Group	
	Amoxicillin	Placebo
Two or more children in family	26%	20%
Smoker in household	39%	32%
Attends day care	24%	15%
Recurrent URTI	32%	27%
Recurrent AOM in family	22%	27%
Recurrent AOM in patient	28%	41%
Allergy	12%	7%
Presented after 3 or more days of illness	49%	44%

Patients were excluded from the trial for the following reasons:  
antibiotic treatment in the previous four weeks; proved  
allergy to amoxicillin; compromised immunity;  
craniofacial abnormalities; Down’s syndrome;  
or being entered in this study before (p. 350).

Aside from the experimental intervention, were the groups treated equally?

Yes. Except for the difference in receiving actual amoxicillin or a placebo

suspension, patients were treated equally. All patients were allowed equal symptomatic treatment, including one drop of decongestant nose spray in each nostril three times daily and use of paracetamol to relieve pain. Patients under one year old received a 120 mg paracetamol suppository, and patients over age one received twice that amount. Parents of all patients kept a diary recording amount of paracetamol used and progression of illness. All patients returned to the general practitioner for follow up on days four and 11, and were visited by the main study investigator at their house six weeks after their initial presentation to the physician.

## 5. What were the results?

How large was the treatment/prevention effect?

How precise was the estimate of the treatment effect?

The table on the following page includes calculations of the treatment effect in terms of risk and risk reduction, as well as the 95% confidence intervals and P-values reported in the paper for the absolute risk reduction.

Additional outcome measures and accompanying P-values that were reported in the paper are shown below.

Median time to cessation of fever	P-value (log-rank test)
Amoxicillin Group: Two days	0.004
Placebo Group: Three days	
Median time to cessation of pain or crying	P-value (log-rank test)
Amoxicillin Group: Eight days	0.432
Placebo Group: Nine days	
Mean analgesic consumption, first three days	P-value (Mann-Whitney U test)
Amoxicillin Group: 1.7 doses	0.018
Placebo Group: 2.5 doses	
Analgesic consumption, first ten days	P-value (Mann-Whitney U test)
Amoxicillin Group: 2.3 doses	0.004
Placebo Group: 4.1 doses	

### Number Needed to Treat

The paper states that seven to eight children need to be treated with amoxicillin in order to improve symptoms at day four in one child. The number needed to treat can be derived in the following manner:

$$\text{NNT} = 1/(\text{Absolute Risk Reduction}) = 1/0.13 = 7.69.$$

I derived the number needed to treat for all categories in the following table.

Size of Treatment Effect						Precision of Treatment Effect	
Outcome	Percent with Outcome	Absolute Reduction	Number Needed to Treat	Relative Reduction	Relative Risk	P Value	95% CI
<b>Persistent Symptoms at Day Four</b>							
Amoxicillin Group	59%	72%-59%=	1/.13=	72%/59%=	1-1.22= -.22	0.03	(1 to 25)
Placebo Group	72%	13%	7.69	1.22	-0.22 x100%=22%		
<b>No Ear Drum Improvement by Day Four</b>							
Amoxicillin Group	77%	83%-77=	1/.06=	83%/77%=	1-1.08= -.08	0.30	(-4 to 16)
Placebo Group	83%	6%	16.66	1.08	-0.08 x100%=8%		
<b>Treatment Failure at Day 11</b>							
Amoxicillin Group	64%	70%-64=	1/.06=	70%/64%=	1-1.09= -.09	0.35	(-6 to 18)
Placebo Group	70%	6%	16.66	1.09	-0.09 x100%=9%		
<b>Middle Ear Effusion Present at Six Weeks</b>							
Amoxicillin Group	64%	67%-64=	1/.03=	67%/64%=	1-1.05= -.05	N/A	(-10 to 16)
Placebo Group	67%	3%	33.33	1.05	-0.05 x100%=5%		

## **6. Will the results help me in caring for my patients?**

### Can the results be applied to my patient care?

Yes, the results can be applied to patients such as the little boy in section one. A.W. meets all of the inclusion criteria. He falls in the correct age range, has presented to his primary care doctor after symptoms for several days, and has a similar clinical appearance of acute otitis media as patients in the study. A.W. does not violate any of the exclusion criteria. He has not been given antibiotics in the last month, and does not have an allergy to antibiotics, a craniofacial abnormality, or Down's syndrome.

I agree with the study investigators' conclusion that antibiotics do not significantly impact recovery from acute otitis media in very young children. Treatment with amoxicillin was statistically significantly different from treatment with placebo in only the following three of the eight outcome measures studied: median duration of fever, mean analgesic consumption during the first ten days, and alleviation of symptoms by day four. Even in these categories, amoxicillin's clinical effect was small. It decreased the median duration of fever by only one day, and symptoms were still present by day four in only 13% fewer patients. Although it reduced analgesic consumption by nearly half over ten days, the reduction of doses in absolute numbers (from four to two doses over ten days) is too small to be clinically important. Since the outcomes of the other five measures were not statistically significant, it is likely that any benefit seen from the use of amoxicillin in these categories is due purely to chance.

### Were all clinically important outcomes considered?

Yes. The outcomes reported above measured potential benefits of amoxicillin. However, study investigators also measured new-onset diarrhea, a possible harmful side effect of amoxicillin. Although new-onset diarrhea occurred more frequently in the group receiving amoxicillin, the differences between the amoxicillin and placebo groups were not statistically significant. Study results are shown in the table on the following page.

Finally, investigators looked at the amount of medication actually taken in each group, a possible source of bias in the study. They found no significant difference in compliance between the groups. The study reports that eighty percent of children in both groups received the full amount prescribed. An additional 15 percent received 95% of the amount prescribed.

Size of Treatment Effect						Precision of Treatment Effect	
Outcome	Percent with Outcome	Absolute Reduction	Number Needed to Treat	Relative Reduction	Relative Risk	P Value	95% CI
<b>Diarrhea at Day Four</b>							
Amoxicillin Group	17%	17%-10%= 7%	1/.07= 14.29	17%/10%= 1.70	1-1.70= -.70  -.70 x100%=70% <sup>1</sup>	N/A	-16 to 2
Placebo Group	10%						
<b>Diarrhea at Day Ten</b>							
Amoxicillin Group	12%	12%-8%= 4%	1/.04= 25	12%/8%= 1.50	1-1.50= -.50  -.50 x100%=50% <sup>1</sup>	N/A	-12 to 4
Placebo Group	8%						

<sup>1</sup> Note that, since diarrhea is a negative outcome, the relative risk reductions in these cases should be interpreted as 70% and 50% decreased chances of getting diarrhea if patients take placebo rather than amoxicillin. However, since the 95% confidence interval includes zero in both cases, neither number can be considered a statistically significant effect.

Are the likely treatment benefits worth the potential harms and costs?

I calculated the cost of treatment based on the fact that seven to eight children need to be treated to alleviate symptoms at day four in one child, and that the cost of a 150 ml bottle of amoxicillin (250 mg/5 ml) is \$7.99 according to [epocrates.com](http://epocrates.com). Assuming that the average two-year-old weighs about 26 lbs and that the course of treatment is 10 days, a two-year-old would require:

26 lbs. = 11.8 kg

40 mg/kg = 11.8 kg x 40 mg = 472 mg per dose

472 mg / (250mg / 5ml) = 9.44 ml per dose (about 1.89 teaspoons)

9.44 ml / 150 ml = 15.9 doses per bottle

3 doses per day x 10 days = 30 doses

Each child would need two bottles, or \$7.99 x 2 = \$15.98 worth of medicine. If seven children must be treated for every one that experiences beneficial effects, then (\$15.98 x 7) = \$111.86 would have to be spent to alleviate symptoms in a single child. When possible side effects such as diarrhea or allergic reactions to the medication are also considered, it does not seem either cost-effective or worthwhile to use amoxicillin to treat very young children who present to their general practitioner with acute otitis media. As the study investigators state, the number needed to treat "is not sufficiently important clinically to prescribe antibiotics for every affected child within this age group (p 353)."



## EVIDENCE-BASED MEDICINE PROJECT

### GRADING CRITERIA

**Total Points Possible: 10**

Area I: Background Data (Medical Context for Question) (0 - 2 points)

- 0 - Inadequate
- 1 - Presents basis for question incompletely or without full understanding of relation to patient
- 2 - Details of patient and basis for search clearly presented

Area II: Question Addressed (0 - 2 points)

- 0 - Very vague, unanswerable
- 1 - Question lacks precision
- 2 - Well-focused question/indicates type of question

Area III: Validity of Study (0 - 2 points)

- 0 - Uses inappropriate guides/inadequate
- 1 - Some points missing
- 2 - Addresses all primary/secondary guides

Area IV: Statistical Data (0 - 2 points)

- 0 - Inadequate
- 1 - Only most basic data from paper presented
- 2 - Detailed description of data or attempt to manipulate data (e.g., calculates relative risk when not given the article)

Area V: Understanding of Implications and Overall Effort (0 - 2 points)

- 0 - No effort to relate study to patient
- 1 - Partially explains relation of study to patient care
- 2 - Detailed understanding of role of research in patient care/makes extra effort (e.g., gets > 1 article, derives number needed to treat)

(Students must achieve a score of at least 4, to Pass this assignment)

**Did Student Complete the Library Modules?**      **Yes**      **No** (If no, deduct 1 point)

Confirmed by: \_\_\_\_\_

**Total Score:** \_\_\_\_\_

**Date Graded:** \_\_\_\_\_

**Faculty Signature:** \_\_\_\_\_

## Clinical Skills Exercise

Loyola Stritch School of Medicine has developed a clinical skills workshop in an effort to further objectify evaluation of clinical performance. This is part of a national trend which moves the traditional Goals and Objectives of a course, towards Competencies and Outcome Objectives. As a Third Year Family Medicine Clerk, you are required to attend a session at the SSOM Clinical Skills Lab, interviewing and counseling a standardized patient. The cases that have been developed are meant to enhance your Family Medicine educational experience, as well as evaluate your knowledge, skill, and attitude. Your performance **will** figure into your final grade.

Succeeding on this important exercise requires you to organize, synthesize, and demonstrate various skill sets you have acquired during your time at Stritch. Concentrating on a thorough, yet efficient, history, organizing that data into written format, as well as using that data to construct problem lists, assessments, and plans, will be critical. Feel free to review your materials from our Clerkship, as well as various tools you have used for the PCM Course.

The Schedule is in your Family Medicine Orientation folder.

- For this encounter you will have 15 minutes to obtain a screening history from a patient. The patient is here with a change of insurance. No physical is expected. 10 minutes into the encounter you will hear an announcement simply to let you know that 10 minutes have gone by and that you have 5 minutes remaining. Please do not respond to this announcement. If you finish the encounter before 15 minutes have gone by you may close the encounter but know that once you exit the room at this point you may not re-enter until later for the counseling portion of the exercise. Before leaving the room, the SP will tell you that when you return, they have some questions about one of the prevention and screening topics you were told to review. (They will specifically tell you which topic).
- Following the patient encounter you will have approximately 10 minutes to complete a Risk Factor and Health Maintenance Outline on the patient you just interviewed. ***DO NOT BRING THE OUTLINE INTO THE ROOM WITH YOU. A CSC MONITOR WILL PICK IT UP.***
- You will have 20 more minutes to counsel the patient on any behaviors that need to be addressed. You should begin by answering the questions the SP has regarding the prevention and screening topic. Continue by counseling on the risk factors that you found.
- The list of conditions from which your screening counseling topic can come from is:
  - Abdominal Aortic Aneurysm
  - Breast Cancer
  - Cervical Cancer
  - Colon Cancer
  - Lung Cancer
  - Osteoporosis
  - Ovarian Cancer
  - Prostate Cancer
  - Testicular Cancer

This new piece will serve as an assessment piece not only for the Family Medicine clerkship but also for SSOM's longitudinal curriculum in Prevention and Screening.

<http://www.stitch.luc.edu/lumen/MedEd/hmps/index.htm>

- To prepare for this you should review the USPSTF Prevention & Screening Recommendations:  
<http://epss.ahrq.gov/ePSS/Topics.do>
- In addition to help you study you can use the very user-friendly link below from the USPSTF that organizes your approach to screening recommendations and counseling.  
<http://epss.ahrq.gov/ePSS/search.jsp>
- As above, 15 minutes into this portion of the encounter you will hear an announcement simply to let you know that 15 minutes have gone by and that you have 5 minutes remaining. Please do not respond to the knock.  
Again, if you finish the encounter before 20 minutes have gone by you may close the encounter but know that once you exit the room you will not meet again with the standardized patient until feedback.  
  
The SP will leave the room and your classmate who has been observing the encounter will come over and give you feedback that will be filmed. During the time your peer is giving you feedback the SP is completing her paperwork in preparation for her feedback.
- The standardized patient will meet with you briefly and provide feedback on your interpersonal skills through use of the Patient Perception Scale.

**PATIENT CHARTS:**

Patient charts are located on the door of each examination room providing basic information about your patient. You will be given time to review the chart before entering the exam room. You may take the chart into the room with you.

**VIDEOTAPING OF ENCOUNTERS:**

All patient encounters are videotaped and reviewed by lab staff and clerkship personnel.

## **GRADES**

### **Overall**

Your final clerkship grade will be based upon a variety of factors.

Clinical Evaluation (determined by the level of competencies achieved) 45% of grade  
(50 pts. possible)

#### **Projects:**

Biopsychosocial (10 pts. possible) 7.5% of grade  
Evidence-Based Medicine (10 pts. possible) 7.5% of grade  
< 4 points on either assignment = fail

#### **Examination**

(30 pts. possible – 100 multiple choice questions = .3 each)  
Points calculated by multiplying number correct by 0.3  
<20 points = fail

30% of grade

**Clinical Skills Exercise** (4 pts. possible)  
<65 points = fail

10% of grade

#### **Final Grade:**

91 -100 points = honors  
86 - 90 points = high pass  
65 - 85 points = pass

< 65 points total= fail

Students scoring less than 65% on the examination, but passing the clinical portion, must remediate the exam only. Students failing either of the assignments will have to remediate the assignment. Students failing the clinical portion only must remediate the clinical rotation, and complete a short answer test at the end of the remediation. Other remediation assignments will be determined on a case-by-case basis according to the student's strengths and weaknesses.

Remediation policies can be accessed online at:

<http://ssom.luc.edu/media/stritchschoolofmedicine/pdfs/2017-Academic-Policy-Manual.pdf>

### **Studying for the Family Medicine Clerkship FINAL EXAM**

Complete the 40 Aquifer Family Medicine CASES.



## Loyola Vertical Curriculum (Self-Study – Not on Final Exam)

Bioethics and Professionalism

Nutrition

Genetics - Dysmorphology and Inborn Errors of Metabolism

## Online Resources

For those wishing to go online for more information, the following sites are recommended.

1. US Practice Guidelines Clearinghouse: [www.guideline.gov](http://www.guideline.gov). Public resource for evidence-based medicine clinical practice guidelines. The Agency for Healthcare Research and Policy.
2. American Academy of Family Physicians: [www.aafp.org](http://www.aafp.org).
3. AMA Journals: [www.ama-assn.org](http://www.ama-assn.org). Abstracts of articles from each of the AMA “Archive” journals.
4. American Medical Students Association (AMSA): [www.amsa.org/well](http://www.amsa.org/well). Webpage of resources relating to medical student well being.

**Podcast Weblinks** – audio and video files distributed over the internet

[www.apple.com/itunes/podcasts](http://www.apple.com/itunes/podcasts)  
[www.accessmedicine.com](http://www.accessmedicine.com)

Free podcatching software  
McGraw-Hill’s subscription service

## Student Evaluation of the Clinical Clerkship

Clerkship comments, faculty/preceptor, and resident evaluations will be available at the **start of each rotation**.

You can edit and save your information during the clerkship, but cannot finalize the evaluation until you have completed all of the components, which must be done by the 2<sup>nd</sup> week after your rotation ends.

**Institutional objectives** and **Clerkship specific objectives** will be released one week before the clerkship ends.

1. **Service specific comments:** Evaluate a minimum of one service.
2. **Lecturer evaluation:** Lecturing and small group faculty will be released as they occur. You have the option to select NA, if the lecture did not occur. You are required to evaluate the entire faculty.
3. **Clinic Preceptors:** Evaluate preceptors you were exposed to in clinic. At least one preceptor has to be evaluated.
4. **Resident evaluation.** At least one resident has to be evaluated, if applicable.

**You have to review and finalize the evaluation prior to two weeks following the end of clerkship.**

**Failure to complete evaluations will be noted as a competency issue, and may take points away from your final grade.**

## **CAREER-RELATED INFORMATION**

### **Family Medicine and Primary/Ambulatory Care**

Recently, individuals from many different specialties have started referring to themselves as primary care physicians. It is important to understand how Family Medicine is unique within the realm of primary care and ambulatory care providers.

#### **Family Medicine:**

Family Medicine is the medical **specialty** that is committed to and provides continuing and comprehensive health care for the individual and the family. It is a specialty that emphasizes breadth of knowledge and which integrates the biological, clinical and behavioral sciences. The scope of Family Medicine encompasses all ages, sexes, each organ system and every disease entity. Family Medicine is the continuing and current expression of the historical medical practitioner and is uniquely defined within the context of the family (AAFP, 1986).

#### **Primary care:**

Primary care is a type of medical care delivery that emphasizes first contact and assumes ongoing responsibility for the patient in both health maintenance and therapy of illness. It is personal care involving a unique interaction and communication between the patient and the physician. It is comprehensive in scope and includes the overall coordination of the care of the patient's health problems, be they biological, behavioral, or social. The appropriate use of consultants and community resources is an important part of effective primary care (American Academy of Family Physicians [AAFP], 1975). While primary care services can and are delivered by individuals from many specialties including Family Medicine, internal medicine, and pediatrics, not all internists and pediatricians are exclusively involved in primary care.

#### **Ambulatory care:**

Ambulatory care is medical care that is provided in the outpatient setting, i.e., outside of the hospital (inpatient) setting. This can include, for example, a physician's office, a clinic attached to a hospital (such as Mulcahy Outpatient Center), and a health department clinic. Patients seen in outpatient settings must be adequately mobile (this can include wheel chair users) and "well" to get to the facility.

### **Family Medicine as a Career**

Family Medicine is rapidly growing in popularity as a career choice for many medical students. In the Article Appendix is an article entitled, "Responses to Questions About Family Medicine as a Career" reprinted from the [American Family Physician](#).

## ***Family Physicians: Who We Are and What We Do***

In the increasingly fragmented world of health care, one thing remains constant: Family physicians are dedicated to treating the whole person. Family medicine's cornerstone is an ongoing, personal patient-physician relationship focusing on integrated care. Unlike other specialties that are limited to a particular organ, disease, age or sex, family medicine integrates care for patients of both genders across the full spectrum of ages within the context of community and advocates for the patient in an increasingly complex health care system.

The nation's nearly 70,000 practicing family physicians are key providers of primary care in the United States, with nearly one in four of all office visits made to general and family physicians annually. In 2001, office visits to general and family physicians numbered more than 210 million - 76 million more than to any other specialty.

The specialty of family medicine was created in 1969 to fulfill the generalist function in medicine, which suffered with the growth of sub-specialization after World War II. Since its creation nearly four decades ago, the specialty has delivered on its promise to reverse the decline of general medicine and provide personal, front-line medical care to people of all socioeconomic strata and in all regions of the United States. Today, family physicians provide the majority of care for America's underserved rural and urban populations. In fact, more than a third of all U.S. counties, with a combined population exceeding 40 million Americans, depend on family physicians to avoid designation as primary care health profession shortage areas.

Because of their extensive training, family physicians are the only specialists qualified to treat most ailments and provide comprehensive health care for people of all ages - from newborns to seniors. Like other medical specialists, family physicians complete a three-year residency program after graduating from medical school. As part of their residency, they participate in integrated inpatient and outpatient learning and receive training in six major medical areas: pediatrics, obstetrics and gynecology, internal medicine, psychiatry and neurology, surgery and community medicine. They also receive instruction in many other areas including geriatrics, emergency medicine, ophthalmology, radiology, orthopedics, otolaryngology and urology.

Providing patients with a personal medical home, family physicians deliver a range of acute, chronic and preventive medical care services. In addition to diagnosing and treating illness, they also provide preventive care, including routine check ups, health-risk assessments, immunization and screening tests, and personalized counseling on maintaining a healthy lifestyle. Family physicians also manage chronic illness, often coordinating care provided by other sub-specialists. From heart disease, stroke and hypertension, to diabetes, cancer and asthma, family physicians provide primary care for the nation's most serious health problems.

Copyright 2006 American Academy of Family Physicians

## Facts about Family Medicine

Average number of hours worked per week: 51  
Average number of patients seen in office per week: 92  
Mean annual income: **\$173.7**

Percentage of family doctors by size of community:

<2,500	2%
2,500 - 19,999	11%
20,000 - 250,000	21%
250,000 - 1 million	24%
> 1 million	41%
Not reported	1%

(For more comprehensive facts about Family Medicine, visit **aafp.org**)

Fellowships commonly completed by family physicians:

- Sports Medicine
- Faculty Development
- Geriatrics
- Obstetrics
- Research
- Rural Medicine
- Preventive Medicine
- Substance Abuse
- Adolescent Medicine

## Family Medicine Residencies

There are numerous accredited **Family Medicine** residencies in the U.S. There are twenty-six residency programs in Illinois. The American Academy of Family Physicians Directory of Family Medicine Residency Programs and the Clerkship/Preceptor Directory is available at <http://www.aafp.org/residencies> .